

Overview and Identification

Strap Sensors are made for direct pipe mounting and temperature measurement of water pipe applications.

The Clamp-On units are for mounting before any insulation is on the pipe and the Spring-Loaded units are for mounting to pipes with up to 2" of insulation using a unique spring sensor extension.

Both units are available with multiple thermistor's or RTD's as shown in the specifications. Enclosure mounting styles come in plastic or metal for both NEMA 1 and NEMA 4 applications and are all plenum rated.

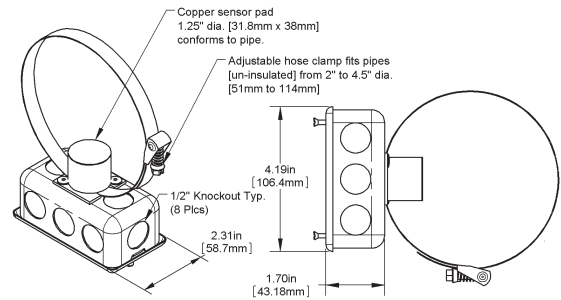

Fig 1: Clamp-On Strap with NEMA 1 J-Box (JB)

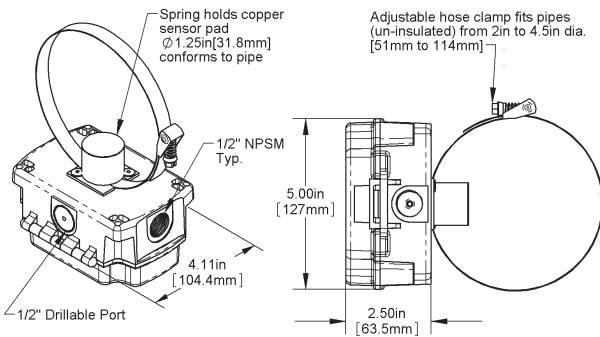

Fig 2: Clamp-On Strap with w/ NEMA 4 BAPI-Box (BB)

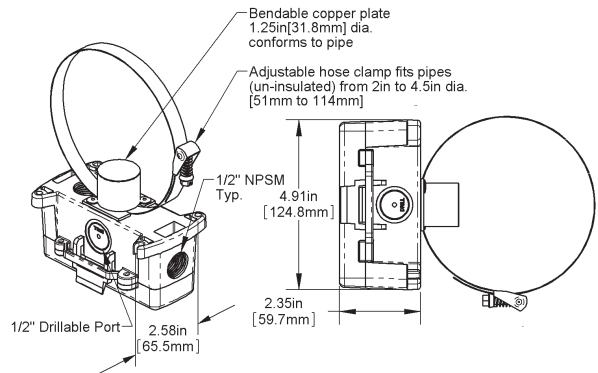

Fig 3: Clamp-On Strap with w/ NEMA 4 BAPI-Box 2 (BB2)

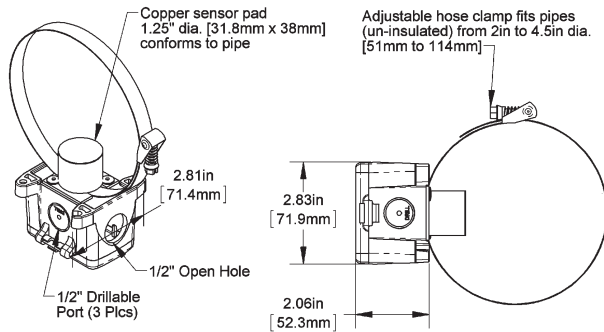

Fig 4: Clamp-On Strap with NEMA 1 BAPI-Box 4 (BB4)
(A Pierceable Knockout Plug is available from BAPI for the open port in the BB4. Part #BA/PAK-100)

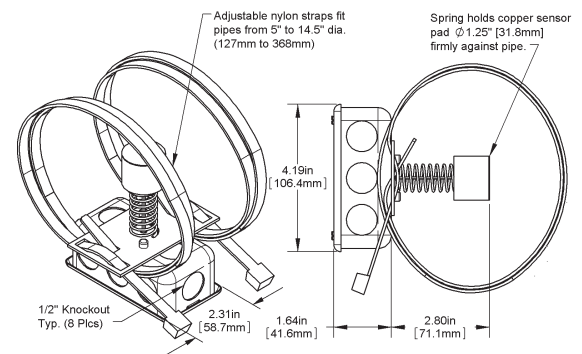

Fig 5: Spring-Loaded Strap w/ NEMA 1 J-Box (JB)

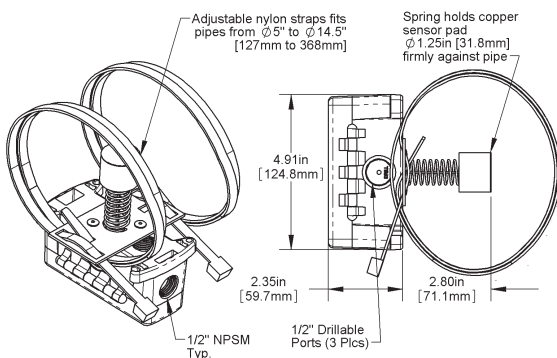

Fig 6: Spring-Loaded Strap w/ NEMA 4 BAPI-Box 2 (BB2)

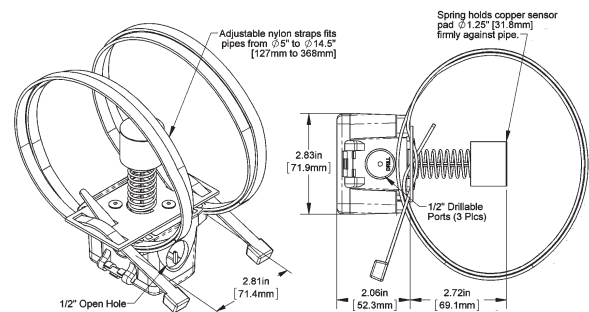
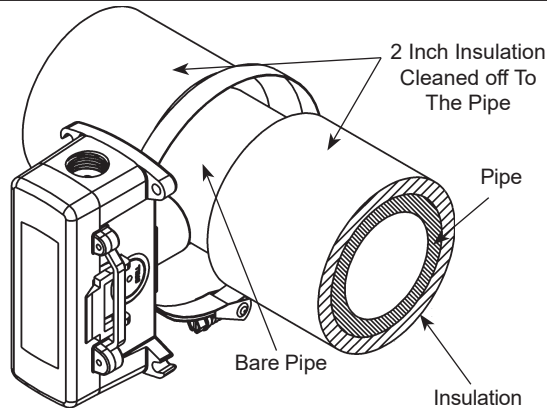
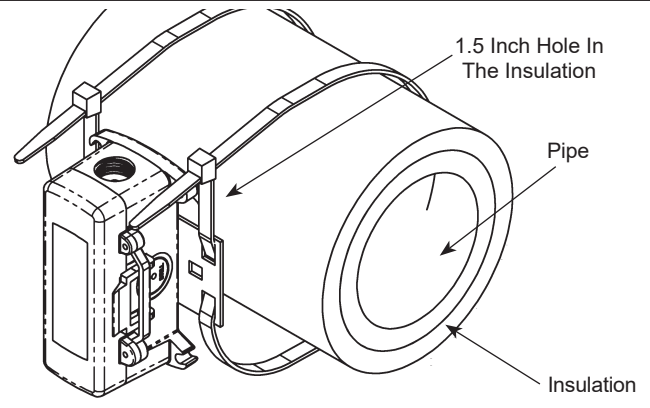

Fig 7: Spring-Loaded Strap w/ NEMA 1 BAPI-Box 4 (BB4)
(A Pierceable Knockout Plug is available from BAPI for the open port in the BB4. Part #BA/PAK-100)

Specifications subject to change without notice.

Mounting**Fig 8:** Typical Clamp-On (-S) Installation**Fig 9:** Typical Spring-Loaded (-STP) Installation

Application: This sensor technique is for reading the fluid temperature in a pipe by reading the temperature of the pipe. Properly installed strap sensors with insulation around the local strap-on sight will offer a very accurate temperature of the water inside the pipe to within .5 °F or better of the inside pipe water temperature.

Clamp-On Unit Installation: BA/#-S

1. Fig 8 shows a typical installation for pipes from 2" to 4.5". Stripping away insulation is OK.
2. Larger pipes can be accommodated by adding another, customer supplied, stainless steel hose clamp extending the possible pipe diameter.
3. If there is insulation, clean away a section of the pipe insulation a minimum of 2" all around the pipe. The copper sensor pad and SS strap must be in direct contact with the metal or plastic pipe. Note: Nothing should be between the copper plate sensor and the bare pipe.
4. Tighten the strap-so that the sensor does not rotate around the pipe and so that the foam is compressed not more than 50% allowing the copper sensor plate to form (bend) to the pipe curvature for maximum temperature conduction. BAPI recommends pre-forming the copper plate by bending it around the pipe with your fingers.
5. After the strap-on sensor is securely mounted, add insulation a minimum of 1" thick and a minimum of 4 pipe diameters on each side of the copper sensor pad. (Example: A 2" pipe should have 8" of insulation on each side of the sensor). Only cover the sensor box to the top of the metal cover plate or to the BB door hinge so termination and servicing can be completed.
6. Terminate per the following Wiring and Termination Section.

Spring Loaded Unit Installation: BA/#-STP

1. Fig 9 shows a typical installation for insulated pipes from 5" to 14". Insulation thickness accommodated is 0.5" to 2.5".
2. Larger pipes can be accommodated by adding another, customer supplied, tie rap strap extending the possible pipe diameter.
3. Make a 1.5 inch diameter hole in the insulation where the sensor is to be placed and clean the pipe from debris. Extend the spring so the copper sensor pad is in direct contact with the metal or plastic pipe. **Note: No debris should be between the copper plate sensor and the bare pipe.** The spring can retract to a minimum insulation thickness of ~.5" compressed to ~2.5" extended.
4. Position the box and sensor over the hole.
5. Tighten the strap so that the sensor spring is compressed no more than 50% allowing the copper sensor plate to form (bend) to the pipe curvature for maximum temperature conduction. BAPI recommends pre-forming the copper plate by bending it around the pipe with your fingers. Extend the spring further by turning it clockwise if the copper sensor plate contact is questionable. The copper sensor plate must be in direct contact with the pipe.
6. After the strap on sensor is securely mounted, add insulation back in (backfill) around the spring extension, using the removed insulation, so that no heat or cold from the pipe can escape.
7. If more insulation is desired, only cover the sensor box to the top of the metal cover plate or to the BB door hinge so termination and servicing can be completed.
8. Terminate per the following Wiring and Termination Section.

Specifications subject to change without notice.

Wiring & Termination

BAPI recommends using twisted pair of at least 22AWG and sealant filled connectors for all wire connections. Larger gauge wire may be required for long runs. All wiring must comply with the National Electric Code (NEC) and local codes. Do NOT run this device's wiring in the same conduit as high or low voltage AC power wiring.

BAPI's tests show that inaccurate signal levels are possible when AC power wiring is present in the same conduit as the sensor wires.

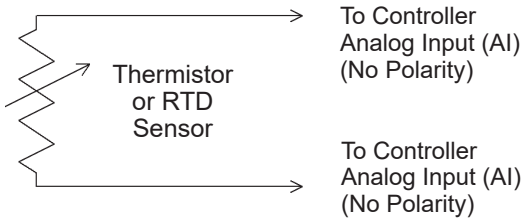

Fig. 10: 2 Wire Lead Wire Termination for Thermistor or RTD

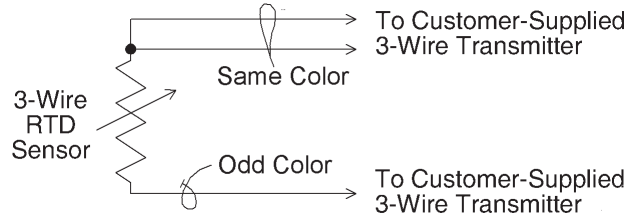

Fig. 11: 3 Wire Lead Wire Termination for RTD

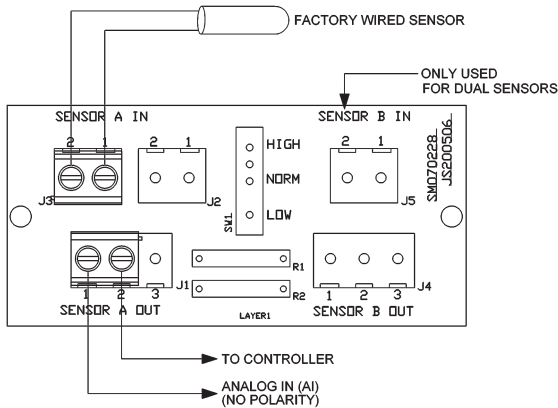

Fig. 12: Terminal Strip (-TS) Option for 2 Wire Sensors Termination

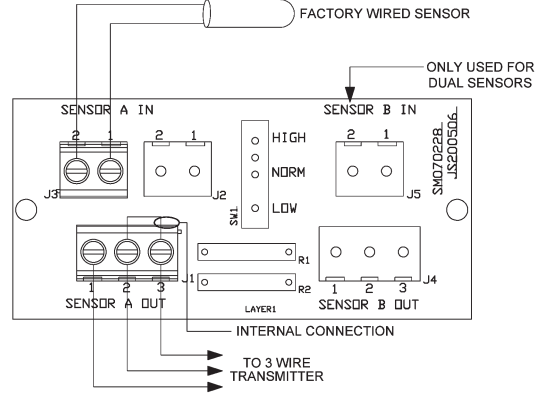

Fig. 13: Terminal Strip (-TS) Option for 3 Wire Sensors Termination

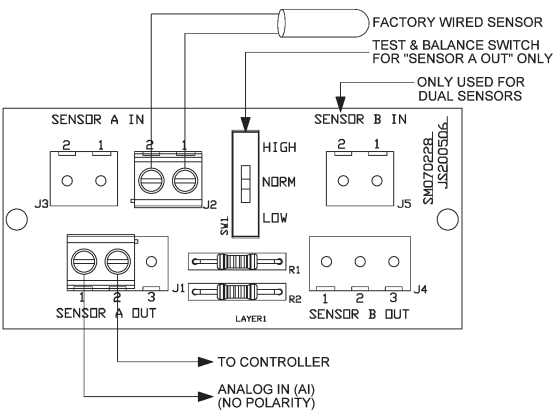

Fig. 14: Test & Balance (-TB) Option for 2 Wire Sensors Termination

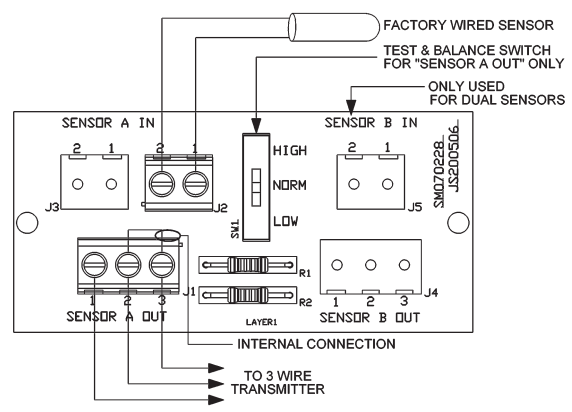

Fig. 15: Test & Balance (-TB) Option for 3 Wire Sensors Termination

Specifications subject to change without notice.



Diagnosics

Possible Problem:

Controller reports higher or lower than actual temperature

Possible Solutions:

- Confirm the input is set up correctly in the front end software
- Check wiring for proper termination & continuity. (shorted or open)
- Disconnect wires and measure sensor resistance and verify the "Sensor" output is correct.

Specifications

Sensor	Passive	Probe	Copper sensor plate, 24 AWG, 1.25" diameter
Thermistor	NTC, 2 wire	Mounting	
RTD	PTC, 2 or 3 wire	Clamp-On	-S , 1/2" Stainless steel worm gear hose clamp
Thermistor	Thermal resistor	Strap-On	-STP , 48" Nylon tie strap, 1/2" wide
Temp. Output	Resistance	Enclosure Types: (Part number designator in bold)	
Accuracy (Std)	±0.36°F, (±0.2°C)	J-Box:	-JB , w/ eight 1/2" knock-outs
Accuracy (High)	±0.18°F, (±0.1°C), [XP] option	BAPI-Box:	-BB , w/ four 1/2" NPSM & one 1/2" drill-out
Stability	< 0.036°F/Year, (<0.02°C/Year)	BAPI-Box 2:	-BB2 , w/ three 1/2" NPSM & three 1/2" drill-outs
Heat dissipation	2.7 mW/°C	BAPI-Box 4:	-BB4 , w/ three 1/2" drill-outs & one 1/2" open port
Temp. Drift	<0.02°C per year	Enclosure Ratings: (Part number designator in bold)	
Probe range	-40° to 221°F (-40° to 105°C)	J-Box:	-JB , NEMA 1
RTD	Resistance Temperature Device	BAPI-Box:	-BB , NEMA 4, IP66, UV Rated
Platinum (Pt)	100Ω or 1KΩ @0°C, 385 curve,	BAPI-Box 2:	-BB2 , NEMA 4, IP66, UV Rated
Platinum (Pt)	1KΩ @0°C, 375 curve	BAPI-Box 4:	-BB4 , IP10 (with spring installed) (IP44 without spring and with Knockout Plug installed in the open port)
Pt Accuracy (Std)	0.12% @Ref, or ±0.55°F, (±0.3°C)	Enclosure Material: (Part number designator in bold)	
Pt Accuracy (High)	0.06% @Ref, or ±0.277°F (±0.15°C), [A] option	J-Box:	-JB , Galvanized steel, UL94H-B
Pt Stability	±0.25°F, (±0.14°C)	BAPI-Box:	-BB , Polycarbonate, UL94V-0, UV rated
Pt Self Heating	0.4 °C/mW @0°C	BAPI-Box 2:	-BB2 , Polycarbonate, UL94V-0, UV rated
Pt Probe range	-40° to 221°F, (-40 to 105°C)	BAPI-Box 4:	-BB4 , Polycarbonate & Nylon, UL94V-0
Nickel (Ni)	1000Ω @70°F, JCI curve	Ambient (Enclosure): 0 to 100% RH, Non-condensing	
Ni Probe range	-40° to 221°F (-40 to 105°C)	J-Box:	-JB , -40°F to 212°F, (-40° to 100°C)
Sensitivity	Approximate @ 32°F (0°C)	BAPI-Box:	-BB , -40°F to 185°F, (-40 to 85°C)
Thermistor	Non-linier	BAPI-Box 2:	-BB2 , -40°F to 185°F, (-40 to 85°C)
	See bapihvac.com "Sensor Specs"	BAPI-Box 4:	-BB4 , -40°F to 185°F, (-40 to 85°C)
1KΩ RTD (Pt)	3.85Ω/°C	Agency:	RoHS, *CE
100Ω RTD (Pt)	0.385Ω/°C		PT= DIN43760, IEC Pub 751-1983, JIS C1604-1989
Nickel (Ni)	2.95Ω/°F for the JCI RTD		*Passive Thermistors 20KΩ and smaller are CE Compliant
Lead wire	22awg stranded		
Wire Insulation	Etched Teflon, Plenum rated		

Specifications subject to change without notice.